



Danley TDH3 Loudspeaker Startup Guide

Unpacking & Inspection

Remove the loudspeaker carefully from the packaging and check for any signs of damage incurred during transit. If there are signs of damage, contact your shipper immediately.

Positioning

Place the TDH3 Loudspeaker in the desired position. Ensure it's on a flat, stable surface. Further details on positioning are on the reverse of this document

Connecting

At the back of the speaker, locate the binding post terminals. Unscrew the top part of the terminals slightly to open up the binding post. Terminals are designed to accept stripped bare wire ends, 4mm banana plugs, or spade terminals. Avoid using crimps on bare wire ends, as these may lead to weak link bar connections.

If using bare wires: Insert the wire into the space between the binding post and the screw cap. Make sure the wire is firmly held when the cap is tightened. Ensure that no stray strands of wire are sticking out, which could cause a short circuit.

If using banana plugs: Simply insert the banana plug into the hole in the middle of the binding post.

Be careful to connect the positive and negative terminals on each connection panel to their matching positive and negative terminals on your amplifier. Misconnections can cause a lack of bass output and a broad, unstable stereo image, indicative of out-of-polarity loudspeakers. If your system displays these symptoms, double-check the wiring polarity.

Settings

The amplifier selection significantly impacts the TDH3 Loudspeaker's performance. Here are a few points to consider:

The TDH3's extended low-frequency response implies relatively low sensitivity, a common trade-off with passive loudspeakers. For best performance, consider amplifiers offering over 400W power output into 8 ohms.

Use of an underpowered amplifier can result in system distortion and increased risk of damage from voice coil overheating.

Safety

Never exceed the loudspeaker's power rating. Regularly check cables for damage and replace if necessary. Keep the loudspeaker dry and away from moisture to prevent damage.

NOTE: This guide assumes the user has a basic understanding of audio setup and safety precautions. Always refer to the user manual provided by the manufacturer for a more detailed setup and safety instructions. If you are uncertain or uncomfortable with any step, consult a professional audio technician.

Understanding the Connection Panel

The TDH3 Loudspeaker features a "bi-wire" connection panel allowing distinct amplification of the bass and mid/high driver. Refer to drawing below for the connection panel's diagram.

For standard wiring, your speaker cable can be connected to either the top or bottom pair of horizontal terminals. If you want to use the bi-wire feature, remove the bridging bars between the vertical pairs of terminals. The upper horizontal pair is for the mid/high while the lower pair connects to the bass driver.

Selecting Speaker Cable

Choose high-quality speaker cables with a minimum 12 AWG/2mm. If your cable runs exceed 15ft/5m, opt for a heavier gauge cable. 10 AWG/2.5mm will suffice for cable runs under 100ft/30m.

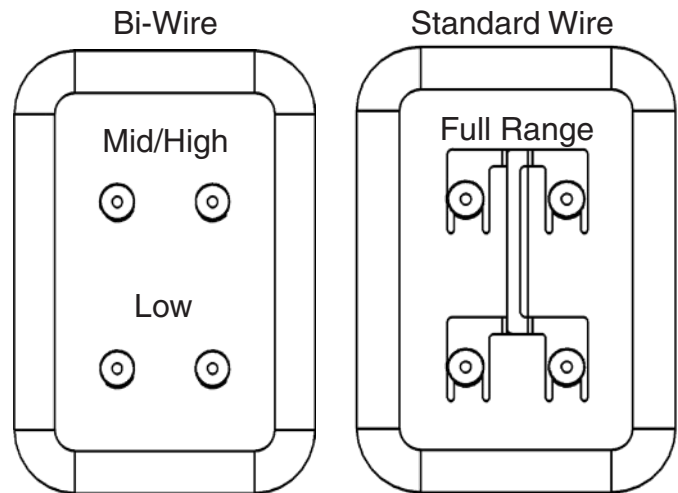

DO NOT connect two amp channels with the bridging bar in place.

Placement Guide

Optimal placement of stereo loudspeakers and studio monitors can significantly improve the accuracy of your sound. The aim is to create an environment where the direct sound from the speakers and the reflected sound from the room's surfaces reach your ears accurately and without causing phase issues. Here are some general guidelines:

Speaker Position

Studio monitors should be set up to form an equilateral triangle with your listening position (mixing desk). Each speaker should be the same distance from each other as they are from you.

Height

The tweeters should be at ear level when you are sitting in your usual mixing position. If they are higher or lower, they should be tilted to aim at your ears.

Orientation

Monitors are designed to be oriented either horizontally or vertically, often depending on the design. It's best to refer to the manufacturer's manual for this, but a good rule of thumb is that the tweeter should be on the outside of the pair, or the tweeter and woofer should be arranged vertically, tweeter above the woofer.

Distance from Walls

Monitors should ideally be placed away from walls and corners to minimize reflections and bass build-up. A general recommendation is to keep them at least a foot away from walls, but the room's size, shape, and composition can alter this advice.

Symmetry

The speakers should be placed symmetrically within the room. Asymmetrical placement can lead to imbalances in the stereo image because sound reflections off the walls can differ.

Room Treatment

Even with optimal speaker placement, untreated room acoustics can still affect your sound. Invest in sound absorption and diffusion panels to treat your room. This can help reduce reflections and standing waves, and dramatically improve your sound quality.

Remember, each room is different, so you may have to experiment a bit to find what works best for your specific space.

